

APPLICATION

For applications where an electrical circuit is used to control a pneumatically-operated device. Used to direct supply air to a pneumatic device when the coil is energized or de-energized, depending on the supply and exhaust air connects.

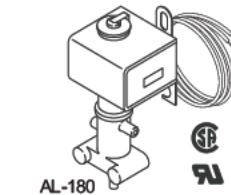
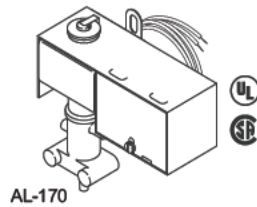

When power is removed from the fan, the fan stops, and the solenoid air valve is de-energized, closing port 1 and bleeding air from the damper actuator through port 3 and out port 2 to atmosphere, closing the exhaust damper.

Figure 1 illustrates a typical application diagram for the AL-170 solenoid air valve.

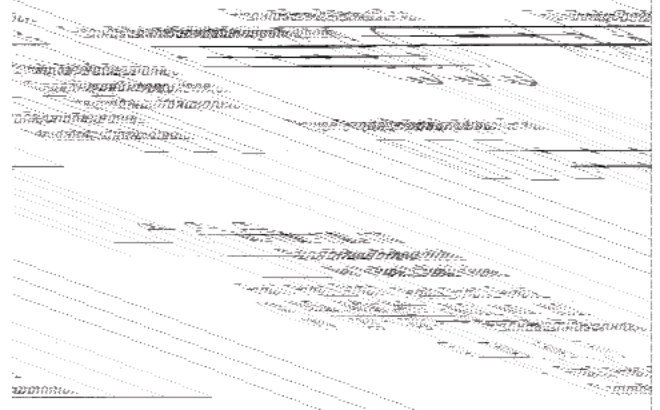

Figure-1 Typical Application Diagram.

FEATURES

- Open frame or junction box construction accommodates a wide variety of NEMA 1 mounting locations.
- Available in 24, 120, 240, Vac models.
- Supplied with 18" electrical leads for ease of installation.
- Corrosion-resistant plastic body.
- Barbed fittings for 1/4" O.D. plastic tubing.

SPECIFICATIONS

Power Input: 5.7 Watts (energized).

Voltage: For available voltages, see Table-1.

Electrical Connections: 18" (457 mm) leads on the coil.

Maximum Inlet Air Pressure: 30 psig (207 kPa). Clean, dry, oil free air is required (reference EN-123).

Air Connections: Three plastic ferrules included for plastic 1/4" tubing (PKG-1141).

N.C.: Normally closed, port 1.

N.O.: Normally open, port 2.

COM: Common, port 3.

Flow Capacity: 0.3 scfm (142 ml/s) at 15 psig (103 kPa) supply with 1 psig (6.9 kPa) drop.

Ambient Temperature Limits:

Shipping, -40 to 150°F (-40 to 65°C).

Operating, 40 to 130°F (4 to 54°C).

Supply Air, 40 to 130°F (4 to 54°C).

Humidity: 5 to 95% RH, non-condensing.

Location: NEMA Type 1.

Mounting: Vertical with solenoid at top (as shown).

Table-1

Solenoid		Voltage (AC 60 Hz)	TAC Replacement Part Numbers
Open Frame	J-Box		
AL-170	AL-180	24	PNR-325-24
AL-171	AL-181	120	PNR-325-120

TYPICAL APPLICATIONS

When power is supplied to the exhaust fan, the fan runs, and the solenoid air valve is energized, closing port 2 and passing main air from port 1 through port 3 to damper actuator, which opens the normally-closed exhaust damper.

INSTALLATION

Inspect the carton for damage. If damaged, notify the appropriate carrier immediately. Inspect the device for obvious damage. Return damaged products.

Requirements

- Job wiring diagrams
- Tools (not provided)
- Training - Installer must be a qualified experienced technician.



Warning: Disconnect the power supply (line power) before installation to prevent electrical shock and equipment damage.

Caution: Make all connections in accordance with the wiring diagram and in accordance with national and local electrical codes. *Use copper conductors only.*

Do not exceed ratings of the devices.

Avoid locations where excessive moisture, corrosive fumes, or vibration is present.

Mounting

Warning: This method requires the use of the enclosure on the coil. An integral mounting plate is provided.

1. Fasten to wall or duct with two #8 sheet metal screws or equivalent.
2. Rotate the solenoid enclosure to position the wiring compartment, if necessary.

Warning: Do not over-tighten as this may cause distortion of plunger tube or damage coil.

CHECKOUT - Go, No Go Test

1. Connect solenoid ports to plastic tubing.
2. Apply air to port 3. Ports 3 and 2 should be connected.
3. Apply power to the solenoid. Ports 3 and 1 should be connected.
4. If ports 3 and 1 are not connected, check to see if the proper voltage is applied.
5. Replace the solenoid with a functional unit if solenoid is powered and ports 3 and 1 are not connected.

MAINTENANCE

Regular maintenance of the total system is recommended to assure sustained optimum performance.

FIELD REPAIR

None. Replace with a functional solenoid.

DIMENSIONAL DATA

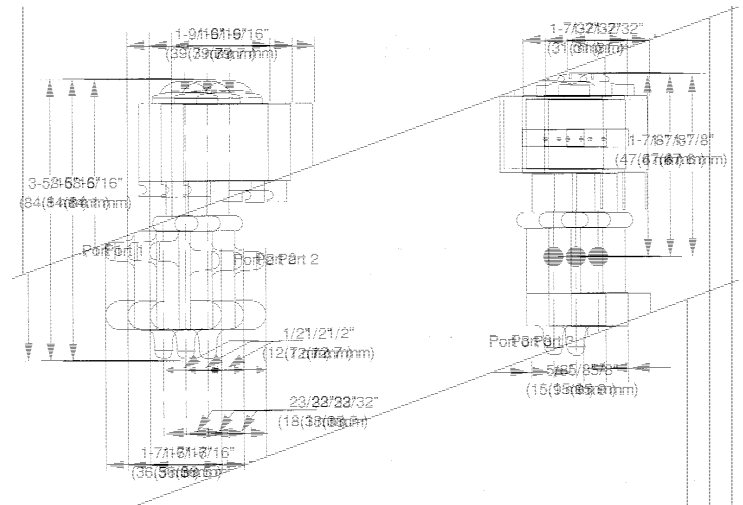

Figure-2 AL-170 Dimensional Drawing.

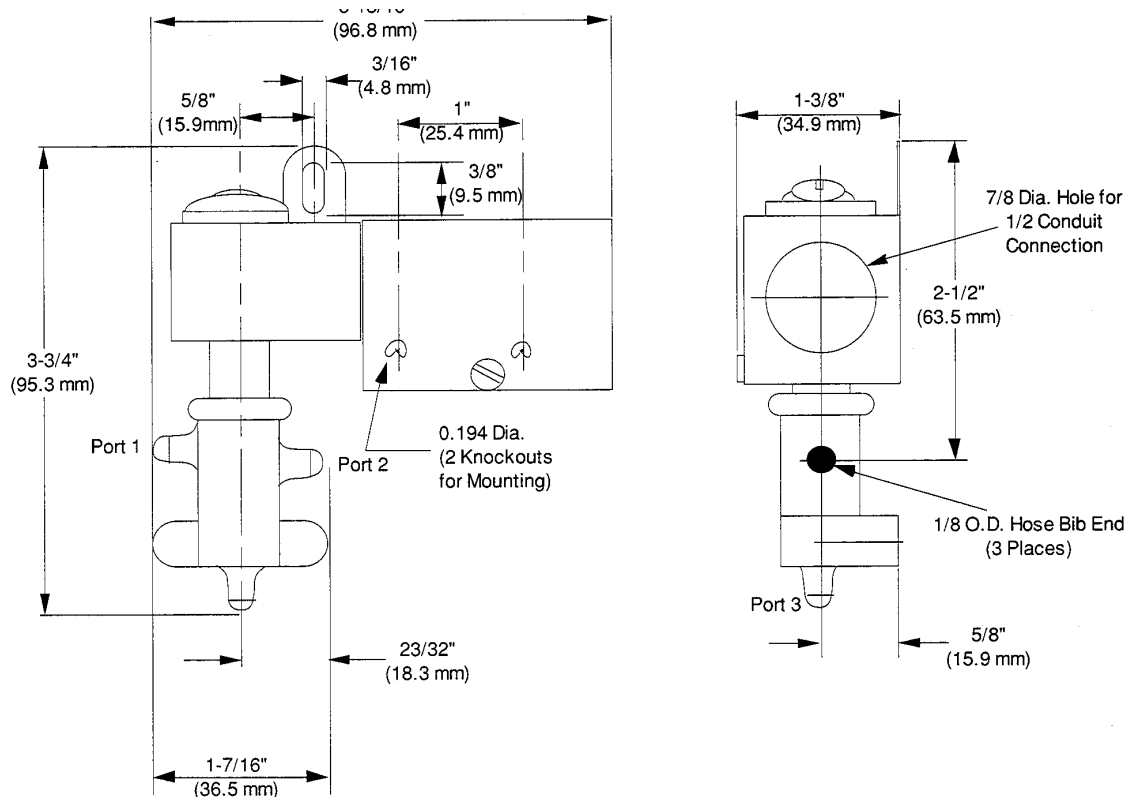

Figure-3 AL-180 Dimensional Drawing.

On October 1st, 2009, TAC became the Buildings business of its parent company Schneider Electric. This document reflects the visual identity of Schneider Electric, however there remains references to TAC as a corporate brand in the body copy. As each document is updated, the body copy will be changed to reflect appropriate corporate brand changes.